



POWERTEC
SOLAR

OFF-GRID
PACKAGES



Freedom begin here

A photograph of a two-story wooden house built on stilts, surrounded by dense tropical forest. The house has a balcony and is partially obscured by large green leaves in the foreground.

NOTE AND ASSUMPTIONS

- To maximize the output wattage of the solar panels, each system was designed to face south or equivalent.
- The solar array's power generation capacity is dependent how much shading and the angle of the rays as they hit the solar panels. Peak power occurs when the rays are at the right angles to the panels, our recommendation is to use a 45 degrees angle if on ground or equivalent on roof. We used an average year round daily peak sun hours of 3 hrs without no shade.
- The efficiency of batteries depends on the temperature at which they are stored. We recommend that lithium-ion batteries and sealed lead-acid batteries (AGM and gel cells) to be stored in a controlled temperature room per manufacturer recommendations

Most batteries are rated at 77°F (25°C), which means their specifications are based on how the battery's cells perform at 25°C. As a rule of thumb, batteries lose about 10% of their rated capacity, as measured by the cells, for every 15-20 degrees below 80°F.

- Each system is designed for 2 days of autonomy (DoA), which is how long you can run your loads without the sun.
- Each panel requires at least of 24ft² of space.

KEY FEATURES

Efficient

- High solar cell efficiency : Monocrystalline 20.1%
- Bypass diodes minimize power drop caused by shade and ensure excellent performance in low-light environments.
- The included MPPT charge controller has a peak efficiency of 97%.

Reliable

- Electroluminescence (EL) tested solar modules; Anti pid technology (apt) hot-spot protect (hsp) traceable quality (tra.Qtm) anti lid technology (alt)
- Corrosion-resistant aluminum frame for extended outdoor use; allowing the panels to last for decades

Intuitive

- Sealed; Gel and Flooded charging algorithm ready
- 4-Stage battery charging process for a rapid; efficient; and safe battery charging

Safe

- Each package is designed with high end quality materials.
- Each component that is used comes with documentation to guide you through.

Expandable

- The Off grid 2.0, 3.0 and the 4.0 system are expandable.

Systems Overview

	OFF-GRID BASIC	OFF-GRID BASIC +	OFF-GRID 2.0	OFF-GRID 3.0	OFF-GRID 3.5	OFF-GRID 4.0	OFF-GRID 4.5	OFF-GRID 6.0	OFF-GRID 8.0
Usage	Ideal for powering your cabins, RVs, trailers, small boats, sheds and tiny houses.	Ideal for cabins, tiny homes, RVs, trailers, boats, sheds and treehouses.	Ideal for traveling across the country in your RV or spending quality time with your family in your cabin in the woods.	Ideal for cabins, tiny homes, RVs, trailers, boats, sheds and treehouses.	Ideal for cabins, tiny homes, RVs, trailers, boats, sheds and treehouses.	Ideal for cabins, tiny homes, RVs, trailers, boats, sheds and treehouses.	Ideal for cabins, tiny homes, RVs, trailers, boats, sheds and treehouses.	Ideal for cabins, tiny homes, RVs, trailers, boats, sheds and treehouses.	This system is ideal for cabins, tiny homes, sheds, treehouses, schools, off grid emergency place and more.
Power	Up to 270Wh per day with a battery bank capacity of 2 days autonomy.	Up to 500Wh per day with a battery bank capacity of 2 days autonomy.	Up to 1200Wh per day with a battery bank capacity of 2 days autonomy.	Up to 1620Wh per day with a battery bank capacity of 2 days autonomy.	Up to 4000Wh per day with a battery bank capacity of 2 days autonomy.	Up to 5000Wh with a battery bank capacity of 2 days autonomy.	Up to 7500 Wh per day with a battery bank capacity of 2 days of autonomy	Up to 15000 Wh per day with a battery bank capacity of 2 days of autonomy.	Up to 30000 Wh per day with a battery bank capacity of 2 days autonomy.
Battery	405W DC, 12V - 104 Ah battery system	405W DC, 12V-208 Ah battery system with a Victron Phoenix 12V 800W Charger inverter	810W DC (2x405W), 12V-420Ah with a Victron Phoenix 12V 1200W inverter	1620W DC (4x405W), powered by a 12V-700Ah battery with a 2000W Charger inverter	2430 WDC (6x405W), powered by a 24V-700Ah battery with a 3000W Charger inverter	2430WDC (6x405W), powered by a 48V-420Ah battery system with a 3800W Charger inverter	3240WDC (8x405W), powered by a 48V-840Ah battery system with a 3800W Charger inverter	8100W DC (20x405W), powered by a 48V-1280Ah battery system with a 8000W charger inverter	9720 WDC powered by a 48V-2250Ah battery system with a 16000W Charger inverter
Loads that the system can run	<ul style="list-style-type: none"> 3 LED lights 2 Phone chargers 	<ul style="list-style-type: none"> 2 LED lights 2 Phone chargers 1 Ceiling fan 1 Laptop charger 1 Internet modem 	<ul style="list-style-type: none"> 3 LED lights 2 Phone charger 1 Ceiling fan 1 Laptop charger 1 LCD 40" TV 1 Stereo system Small 12V DC Fridge 	<ul style="list-style-type: none"> 4 LED lights 1 Phone charger 1 Ceiling fan 1 Laptop charger 1 LCD 40" TV 1 Submersible pump 1 Coffee machine / Kettle Small 12V DC Fridge 	<ul style="list-style-type: none"> 8 LED lights 2 Phone chargers 1 Ceiling fan 1 Laptop charger 1 LCD 40" TV 1 Submersible pump Coffee machine / Kettle 1 Jet pump 1 Internet modem Small 12V DC Fridge 	<ul style="list-style-type: none"> 10 LED lights 3 Phone chargers 1 Ceiling fan 1 Laptop charger 1 LCD 40" TV 1 Submersible pump 1 Stereo system 1 AC Fridge 1 Coffee machine / Kettle 1 Toaster 1 Hair dryer 1 Internet modem 	<ul style="list-style-type: none"> 10 LED lights 4 Phone chargers 1 Ceiling fan 1 Laptop charger 1 LCD 40" TV 2 Submersible pumps 1 Stereo system 1 Coffee machine / Kettle 1 Toaster 1 Hair dryer 1 Internet modem 1 Dish satellite 1 Blender machine 1 Furnace blower 1 Cell signal booster 1 Freezer 	<ul style="list-style-type: none"> 40 LED lights 3 Phone chargers 3 Ceiling fan 2 Laptop chargers 2 LCD 40" TVs 1 Washing machine 2 Jet pumps 1 Stereo system 2 Fridges 2 Coffee machines / Kettles 1 Internet modem + router 1 Dish satellite 1 Blender 1 Diesel Heater 1 Cells signal booster 1 Submersible pump 1 Small off grid electric cloth dryer 1 Air conditioner 2 Bathroom fans 1 Freezer 1 Hair dryer 1 Vacuum cleaner 1 Furnace blower 1 Water cooler 	<ul style="list-style-type: none"> 10 LED lights 2 Phone chargers 3 Ceiling fans 2 Laptop chargers 4 LCD 40" TVs 1 Washing machine 1 Jet pump 1 Stereo system 1 Fridge 1 Coffee machine/Kettle 1 Internet modem 1 Dish satellite 1 Blender 1 Diesel Heater 1 Cells signal booster 1 Submersible pump 1 Small off grid electric cloth dryer 1 Air conditioner 2 Bathroom fans 1 Freezer 1 Hair dryer 1 Vacuum cleaner 1 Furnace blower 1 Water cooler
	OFF-GRID BASIC	OFF-GRID BASIC +	OFF-GRID 2.0	OFF-GRID 3.0	OFF-GRID 3.5	OFF-GRID 4.0	OFF-GRID 4.5	OFF-GRID 6.0	OFF-GRID 8.0



POWERTEC
SOLAR

Powertec Solar Inc.
1433 Erin Street
Winnipeg, MB
Phone: 855-776-9371

OFF GRID 1.0.12



- The "Off Grid 1.0.12" solar system is able to run a load up to 270Wh per day with a battery bank capacity of 2 days autonomy, that's how long you can run your loads with minimum sunlight.
- The single 405W DC, 12V - 104 Ah battery system is ideal for powering your cabins, RVs, trailers, small boats, sheds and tiny houses. If portability and efficiency are your priority, this system is attended to do just that while powering your small loads like LED lights and cell phone chargers. (see chart)
- The batteries are essential for an off-grid system. We recommend keeping these batteries between 15 °C and up to 38 °C to maximize their life and efficiency.
- The following or equivalent loads that the system can run (see table 1)

OFF GRID 1.0.12

Load	QTY	AC Watts	Hrs/ Day	Days/ Week	Wh/day
LED	3	10	5	7	150
Phone charger	2	7	4	7	56

Table 1 : Load example



OFF GRID 1.0.12

**Victron Bluesolar
MPPT 75 | 15
Charge controller**

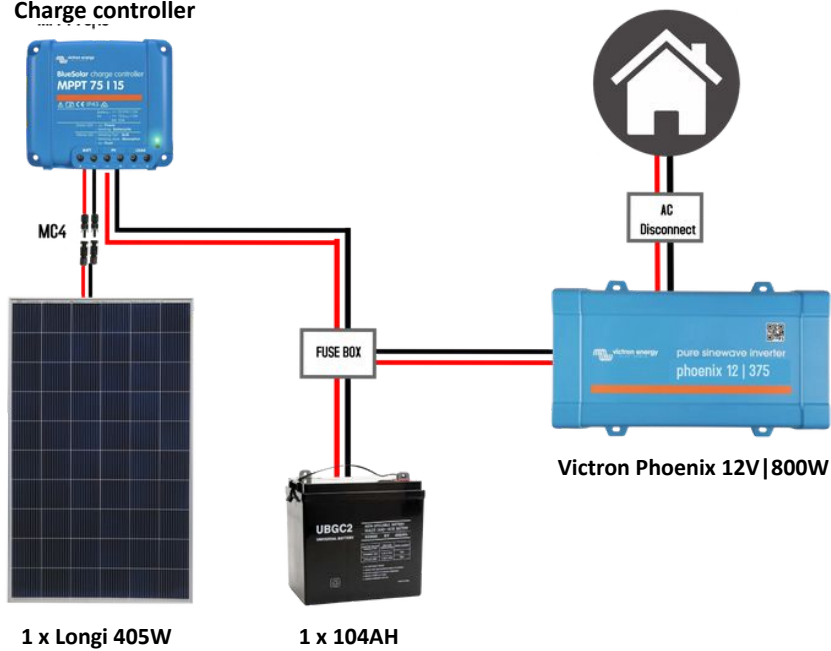

*** Items is subject to change

OFF GRID 1.5.12



- The "Off Grid 1.5.12" solar system is able to run a load between 500Wh per day with a battery bank capacity of 2 days autonomy, that's how long you can run your loads with minimum sunlight.
- The Off Grid 1.5.12 solar system is equipped with a single 405W DC Solar Panel, with a 12V - 208 Ah battery system.
- The system is ideal for powering your cabins, RVs, trailers, small boats, sheds and tiny houses. If portability and efficiency are your priority, this system is attended to do just that while powering your small loads like LED lights and cell phone chargers. (see chart)
- The batteries are essential for an off-grid system. We recommend keeping these batteries between 15 °C and up to 38 °C to maximize their life and efficiency.
- The following or equivalent loads that the system can run (see table 1)

OFF GRID 1.5.12

Load	QTY	AC Watts	Hrs/ Day	Days/ Week	Wh/day
LED Lights	2	10	3.5	7	70
Ceiling Fan	1	60	1.5	7	90
Phone Charger	2	7	4	7	56
Laptop charger	1	65	3	7	195
Internet Modern	1	20	4	7	80

Table 1 : Load example



OFF GRID 1.5.12

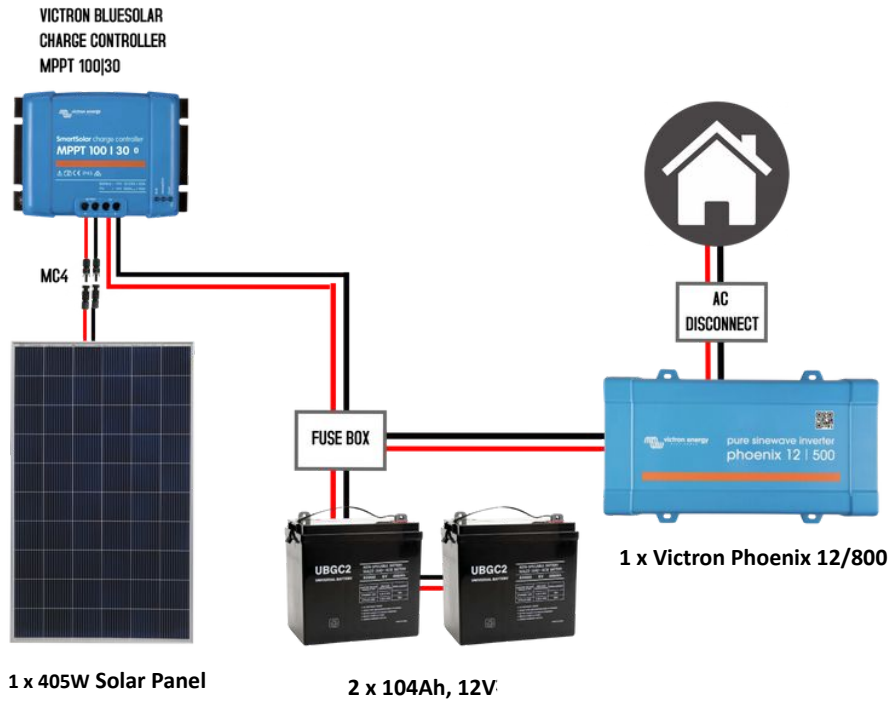

*** Items is subject to change

OFF GRID 2.0.12



- The "Off-grid 2.0.12" solar system is capable of running a loads of up to 1200Wh per day with a battery bank capacity of 2 days autonomy. This is how long you can run your loads without sunlight.
- Whether you are traveling across the country in your RV or spending quality time with your family at your cabin in the woods for the weekend, the Off Grid 2.0.12 system is an 810W DC, 12V-420Ah with a 1200W inverter capable of powering your non-demanding household appliances and a small 12VDC off grid refrigerator (see table below). The 1200W inverter has enough power to run not only the list below, but also digital cameras, small power tools, game consoles, DVD players, and a tablet.
- The batteries are essential for an off-grid system. We recommend keeping these batteries between 15 °C and up to 38 °C to maximize their life and efficiency.
- The following or equivalent are loads that the system can run (see table 1)

OFF GRID 2.0.12

Loads	QTY	AC Watts	Hrs/ Day	Days/ Week	Wh/day
LED	3	10	6	7	180
Phone Charger	2	7	4	7	56
40" LED TV	1	80	1	7	80
Stereo System	1	100	1	7	100.0
Ceiling Fan	1	60	1	7	60
Laptop charger	1	65	2	7	130
Small 12V DC Fridge	1	50	8	7	400

Table 1 : Load example

OFF GRID 2.0.12

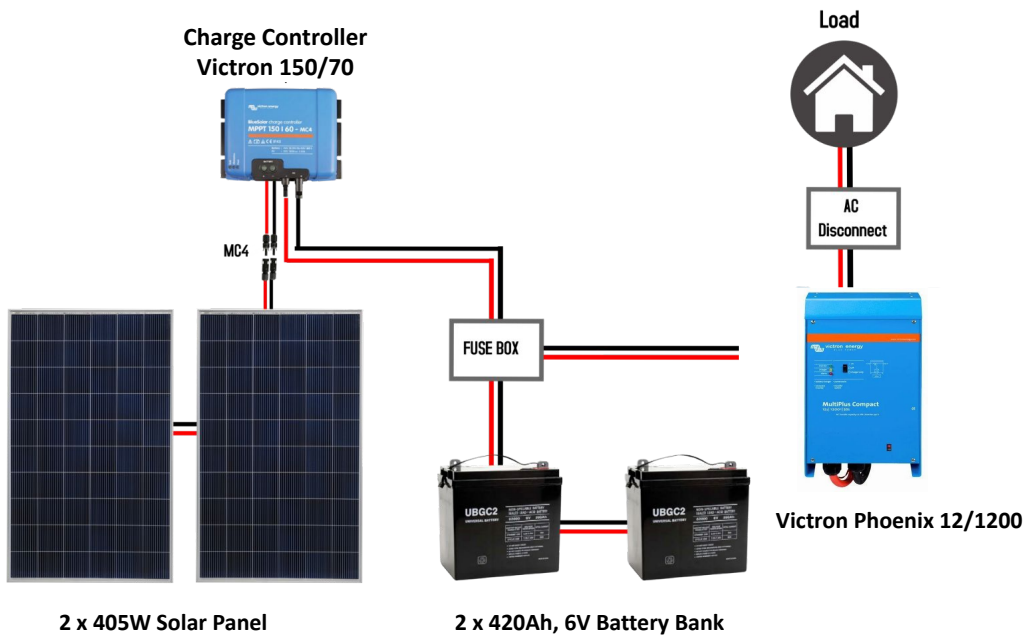

*** Items is subject to change
***Battery upgradable to Lithium

OFF GRID 3.0.12



- The "Off-grid 3.0.12" solar system is capable of running loads up to 1700Wh per day with a battery bank capacity of 2 days autonomy. That's how long you can run your loads without sunlight.
- The "Off Grid 3.0.12" system has 1620W DC, powered by a 12V-700Ah battery system that gives you the freedom to run more loads than the "Off Grid 1.5.12" system. This system is able to run the low powered appliances. This system is ideal for cabins, tiny homes, RVs, trailers, boats, sheds and treehouse.
- The batteries are essential for an off-grid system. We recommend keeping these batteries between 15 °C and up to 38 °C to maximize their life and efficiency.
- The following or equivalent are loads that the system can run

OFF GRID 3.0.12

Load	QTY	AC Watts	Hrs/ Day	Days/ Week	Wh/day
LED	4	12	6	7	288
Submersible pump	1	450	1	7	450
Phone Charger	1	7	4	7	28
40" LED TV	1	80	1	7	80.0
Coffee Machine / Kettle	1	1000	0.2	5	200
Ceiling Fan	1	60	1	7	60
Laptop charger	1	65	2	7	130
Small 12V DC Fridge	1	50	8	7	400

Table 1 : Load example



OFF GRID 3.0.12

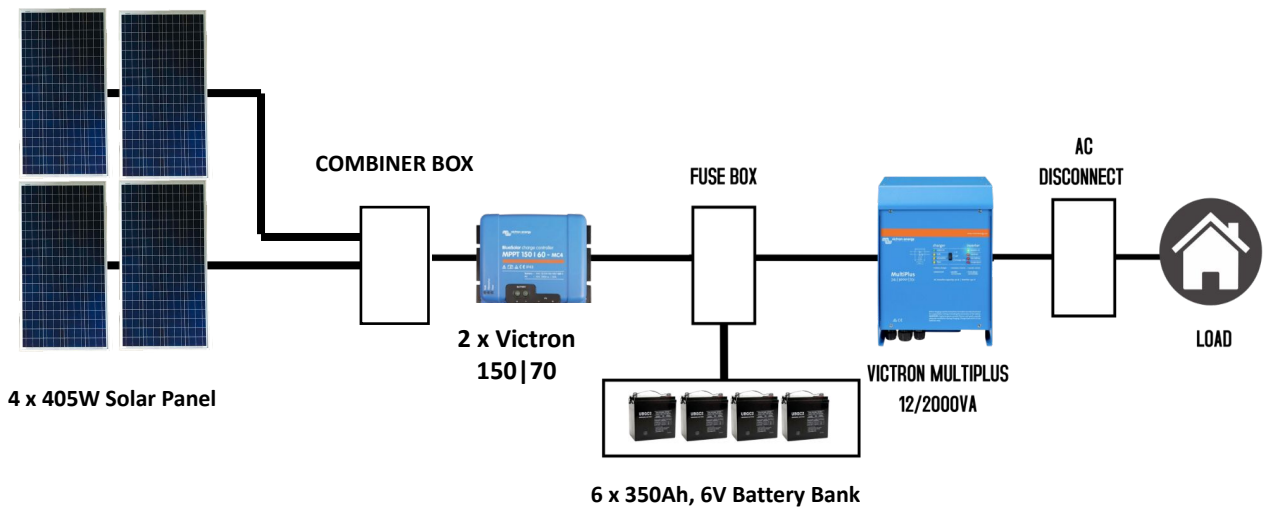

*** Items is subject to change

OFF GRID 3.5.24



- The "Off-grid 3.5.24" solar system is capable of running loads up to 4000Wh per day with a battery bank capacity of 2 days autonomy. That's how long you can run your loads without sunlight.
- The "Off Grid 3.5.24" system has 2430W DC, powered by a 24V-350Ah battery system that gives you the freedom to run more loads than the "Off Grid 3.0.12" system with a 3000W charger inverter that also capable of charging your battery with a generator
- This system is able to run off grid powered appliances and some higher demanding appliance like coffee machine, kettle and a submersible pump. This system is ideal for cabins, tiny homes, RVs, trailers, boats, sheds and treehouse.
- The batteries are essential for an off-grid system. We recommend keeping these batteries between 15 °C and up to 38 °C to maximize their life and efficiency.
- The following or equivalent are loads that the system can run (see Table 1)

OFF GRID 3.5.24

Load	QTY	AC Watts	Hrs/ Day	Days/ Week	Wh/day
LED	8	10	8	7	640
Submersible pump	1	450	1	7	450
Phone Charger	2	7	4	7	56
40" LED TV	1	80	1	7	80.0
Coffee Machine / Kettle	1	1000	0.2	5	200
Ceiling Fan	1	60	1	7	60
Laptop charger	1	65	2	7	130
Jet Pump (1/2 HP)	1	400	2	7	800
Internet Modern	1	20	6	7	120
AC Fridge	1	350	4	7	1400

Table 1 : Load example

OFF GRID 3.5.24

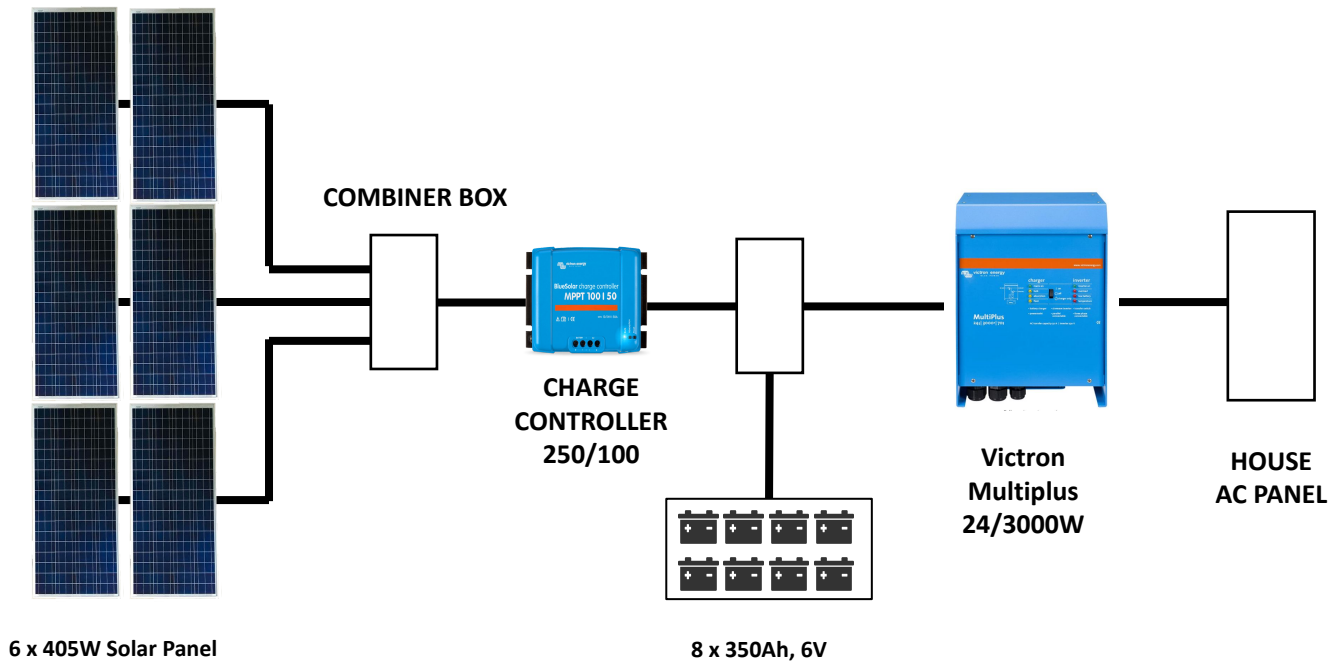

*** Items is subject to change

OFF GRID 4.0.48



- The "Off-grid 4.0.48 "solar system is capable of running a load up to 5000 Wh per day with a battery bank capacity of 2 days of autonomy. That's how long you can run your loads without sunlight.
- The "Off Grid 4.0.48" system has 2430W DC, powered by a 48V-420Ah battery bank system that will give you the freedom to run more loads than the "Off Grid 3.0" system. This system is able to run off grid appliances and some higher demanding appliance like coffee machine, kettle and a submersible pump, small AC fridge, small washing machine, (see table 1 for loads examples). This system is ideal for cabins, tiny homes, RVs, trailers, boats, sheds and treehouse.
- The batteries are essential for an off-grid system. We recommend keeping these batteries between -10 °C to 20 °C to maximize their life and efficiency.

OFF GRID 4.0.48

Load	QTY	AC Watts	Hrs/ Day	Days/ Week	Wh/day
LED Light	10	10	7	7	700
Ceiling fan	1	60	2	7	120
Submersible Pump	1	400	2	7	800
40" LED TV	1	80	2	6	160
Stereo	1	100	2	5	200
AC Fridge	1	350	7	7	2450
Coffee Machine/ Kettle	1	1000	0.2	7	200
Phone Charger	3	7	4	7	84
Laptop charger	1	65	3	7	195

Table 1 : Load example

OFF GRID 4.0.48

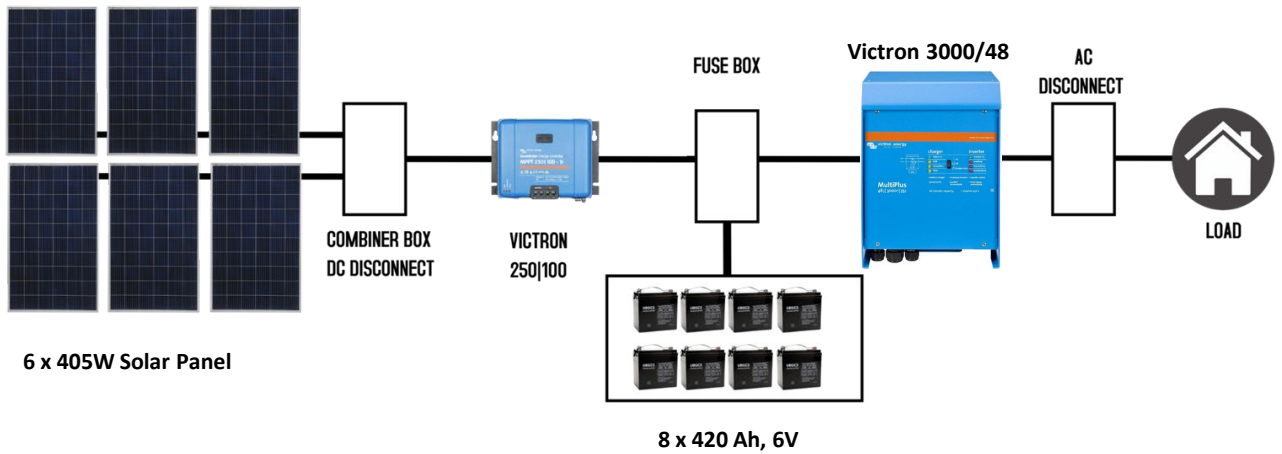

*** Items is subject to change

OFF GRID 4.5.48



- The “Off-grid 4.5.48 ”solar system is capable of running a load up to 7500 Wh per day with a battery bank capacity of 2 days of autonomy. That's how long you can run your loads without sunlight.
- The "Off Grid 4.5.48" system has 3240W DC, powered by a 48V-840Ah battery bank system that will give you the freedom to run more loads than the "Off Grid 4.0.48" system. This system is able to run off grid appliances and some higher demanding appliance like coffee machine, kettle and a submersible pump, small AC fridge, small washing machine, (see table 1 for loads examples). This system is ideal for cabins, tiny homes, RVs, trailers, boats, sheds and treehouse.
- The batteries are essential for an off-grid system. We recommend keeping these batteries between 15 °C and up to 38 °C to maximize their life and efficiency.

OFF GRID 4.5.48

Load	QTY	AC Watts	Hrs/ Day	Days/ Week	Wh/day
LED Light	10	10	8	7	800
Ceiling fan	1	60	3	7	180
Submersible Pump	2	450	2	7	1800.0
40" LED TV	1	80	3	6	240
Stereo	1	100	2	5	200
Fridge	1	350	8	7	2800
Coffee Machine/ Kettle	1	1000	0.2	7	200
Phone Charger	4	7	4	7	112
Laptop charger	1	65	3	7	195
Toaster	1	1200	0.4	7	480
Hair Dryer	1	1500	0.2	7	300
Internet Modern + Router	1	30	8	7	240

Table 1 : Load example

OFF GRID 4.5.48

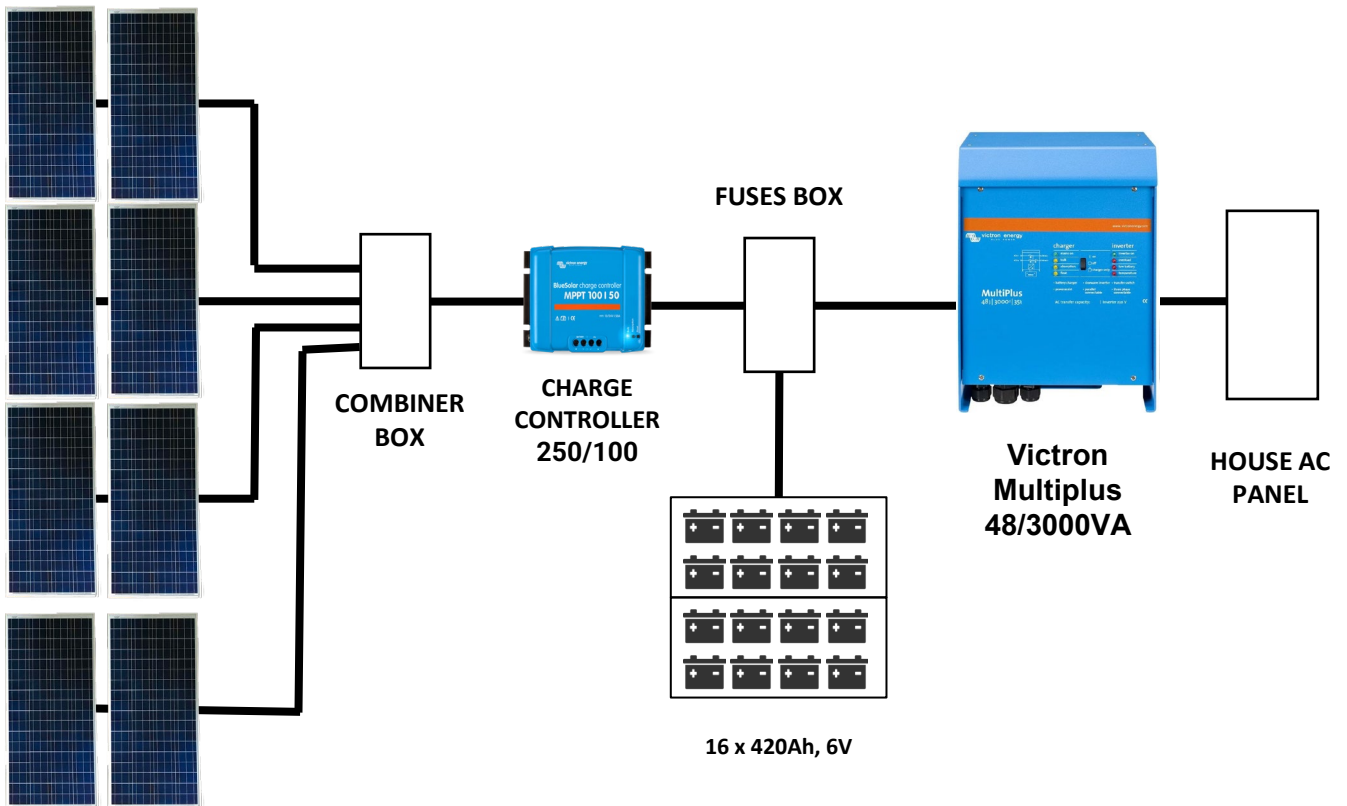

8 x 405W Solar Panel

*** Items is subject to change

OFF GRID 6.0.48



- The "Off-grid 6.0.48 "solar system is capable of running loads up to 15000Wh to 17 000Wh per day with a battery bank capacity of 2 days autonomy. That's how long you can run your loads without sunlight.
- The "Off Grid 6.0.48" system has 8100W DC, powered by a 48V-1260Ah battery system that gives you the freedom to run more loads than the "Off Grid 4.0.48" system. This system is able to run off grid appliances and higher demanding appliance like coffee machine, kettle, submersible pump, AC fridge, small washing machine, microwave oven, air conditioner windows unit, dehumidifier and much more (see table for loads examples). This system is ideal for cabins, tiny homes, RVs, trailers, boats, sheds and treehouse.
- The batteries are essential for an off-grid system. We recommend keeping these batteries between 15 °C and up to 38 °C to maximize their life and efficiency.
- The following or equivalent are loads that the system can run (see table 1)

OFF GRID 6.0.48

Load	QTY	AC Watts	Hrs/ Day	Days/ Week	Wh/day
LED	40	10	5	7	2000
Ceiling Fan	3	60	3	7	540
Washing Machine	1	500	1	1	500
Jet Pump (1/2 HP)	2	400	2	7	1600.0
40" LCD TV	2	140	3	7	840
Stereo	1	100	4	7	400
Fridge	1	350	8	7	2800
Coffee Machine/ Kettle	1	1000	0.5	7	500
Phone Charger	3	7	4	7	84
Laptop Charger	2	65	4	7	520
Internet modem	1	30	6	7	180
Dish Satellite	1	30	4	7	120
Blender	1	350	1	4	350
Furnace Blower	1	350	4	7	1400
Cells Signal Booster	1	3	8	7	24
HRV	1	125	7	7	875
Freezer	1	350	7	7	2450

Table 1 : Load example

OFF GRID 6.0.48

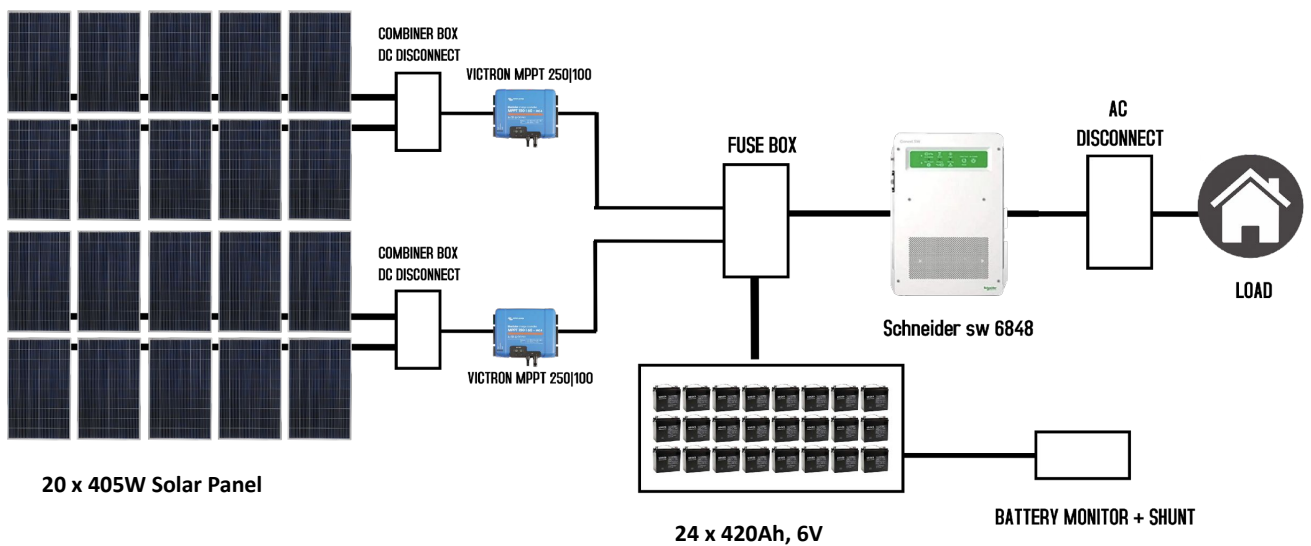

*** Items is subject to change



OFF GRID 8.0.48

- The "Off-grid 8.0.48 "solar system is capable of running loads up to 30 000.Wh per day with a battery bank capacity of 2 days autonomy. That's how long you can run your loads without sunlight.
- The "Off Grid 8.0.48" system has 9720W DC powered by a 48V-2550Ah battery system that gives you the freedom to run more loads than the "Off Grid 6.0" system. This system is able to run your house appliances and higher demanding appliance within the design range (see table for loads examples). This system is ideal for cabins, tiny homes,sheds,treehouse, schools, off grid emergency place and more.
- The batteries are essential for an off-grid system. We recommend keeping these batteries between 10 °C to 20 °C to maximize their life and efficiency.
- The following or equivalent are loads that the system can run

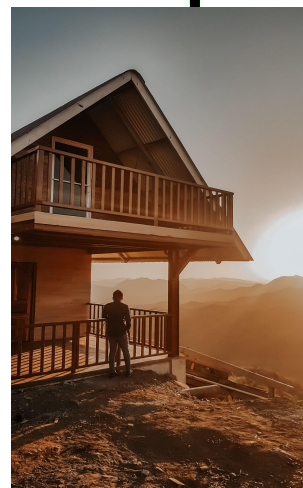

Load	QTY	AC Watts	Hrs/ Day	Days/ Week	Wh/day
LED Lights	50	16	5	7	4000
Ceiling fan	3	60	4	7	720
Washing Machine	1	500	1	2	500
Jep pump (1/2) HP	1	400	2	5	800.0
40" LCD TV	4	140	4	7	2240
Stereo	1	100	4	7	400
Fridge	1	350	8	7	2800
Coffee Machine/ Kettle	2	1000	1	4	2000
Phone Charger	2	7	4	7	56
Laptop Charger	2	65	4	7	520
Internet modern	1	30	6	7	180
Dish Satellite	1	30	4	7	120
Blender	1	350	1	4	350
Diesel Heater (Preheat + small load while running)	1	350	4	5	1400
Cells Signal Booster	1	3	8	7	24
Submersible pump	1	450	4	7	1800
Small Off grid Electric Cloth Dryer	1	3400	2	4	6800
Room Air Conditioner	1	1100	4	4	4400
Bathroom Fan	1	60	2	4	120
Freezer	1	300	8	7	2400
Hair Dryer	1	1500	0.5	4	750
Vacuum Cleaner	1	500	0.5	3	250
Furnace Blower	1	350	6	4	2100
HRV	1	125	8	5	1000
Water Cooler	1	90	5	4	450
Bathroom Fan	1	350	2	4	700



System Design

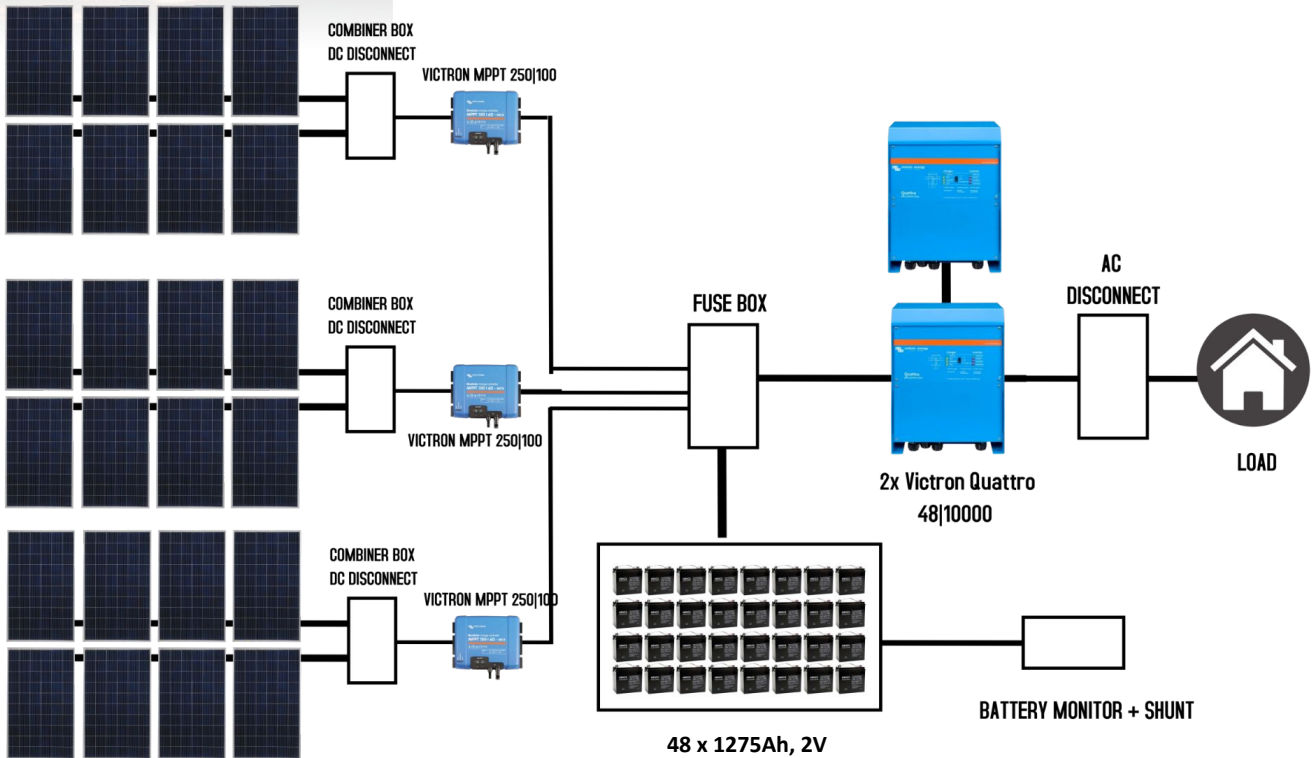

24 x 405W Solar Panel