



POWERTEC
SOLAR

OFF-GRID 4.5.48



Freedom begin here

A photograph of a two-story wooden house built on stilts, nestled in a dense forest. The house has a balcony and is surrounded by tall trees and large green plants in the foreground. The lighting is soft, suggesting an overcast day.

NOTE AND ASSUMPTIONS

- To maximize the output wattage of the solar panels, each system was designed to face south or equivalent.
- The solar array's power generation capacity is dependent how much shading and the angle of the rays as they hit the solar panels. Peak power occurs when the rays are at the right angles to the panels, our recommendation is to use a 45 degrees angle if on ground or equivalent on roof. We used an average year round daily peak sun hours of 3 hrs without no shade.
- The efficiency of batteries depends on the temperature at which they are stored. We recommend that lithium-ion batteries and sealed lead-acid batteries (AGM and gel cells) to be stored in a controlled temperature room with a minimum temperature of 0 degrees Celsius at worse.

Most batteries are rated at 77°F (25°C), which means their specifications are based on how the battery's cells perform at 25°C. As a rule of thumb, batteries lose about 10% of their rated capacity, as measured by the cells, for every 15-20 degrees below 80°F. For a larger battery bank, we recommend building an insulated shelter with small controlled fans (small heater for winter) to increase life of the batteries.

- Each system is designed for 2 days of autonomy (DoA), which is how long you can run your loads without the sun.
- Each panel requires at least of 24ft² of space.

KEY FEATURES

Efficient

- High solar cell efficiency : Monocrystalline 20.1%
- Bypass diodes minimize power drop caused by shade and ensure excellent performance in low-light environments.
- The included MPPT charge controller has a peak efficiency of 97%.

Reliable

- Electroluminescence (EL) tested solar modules; Anti pid technology (apt) hot-spot protect (hsp) traceable quality (tra.Qtm) anti lid technology (alt)
- Corrosion-resistant aluminum frame for extended outdoor use; allowing the panels to last for decades

Intuitive

- Sealed; Gel and Flooded charging algorithm ready
- 4-Stage battery charging process for a rapid; efficient; and safe battery charging

Safe

- Each package is designed with high end quality materials.
- Each component that is used comes with documentation to guide you through.

Expandable

- The Off grid 2.0, 3.0 and the 4.0 system are expandable.

OFF GRID 4.5.48



- The "Off-grid 4.5.48 "solar system is capable of running a load up to 7500 Wh per day with a battery bank capacity of 2 days of autonomy. That's how long you can run your loads without sunlight.
- The "Off Grid 4.5.48" system has 3240W DC, powered by a 48V-840Ah battery bank system that will give you the freedom to run more loads than the "Off Grid 4.0.48" system. This system is able to run off grid appliances and some higher demanding appliance like coffee machine, kettle and a submersible pump, small AC fridge, small washing machine, (see table 1 for loads examples). This system is ideal for cabins, tiny homes, RVs, trailers, boats, sheds and treehouse.
- The batteries are essential for an off-grid system. We recommend keeping these batteries between 15 °C and up to 38 °C to maximize their life and efficiency.

OFF GRID 4.5.48

Load	QTY	AC Watts	Hrs/ Day	Days/ Week	Wh/day
LED Light	10	10	8	7	800
Ceiling fan	1	60	3	7	180
Submersible Pump	2	450	2	7	1800.0
40" LED TV	1	80	3	6	240
Stereo	1	100	2	5	200
Fridge	1	350	8	7	2800
Coffee Machine/ Kettle	1	1000	0.2	7	200
Phone Charger	4	7	4	7	112
Laptop charger	1	65	3	7	195
Toaster	1	1200	0.4	7	480
Hair Dryer	1	1500	0.2	7	300
Internet Modern + Router	1	30	8	7	240

Table 1 : Load example

OFF GRID 4.5.48

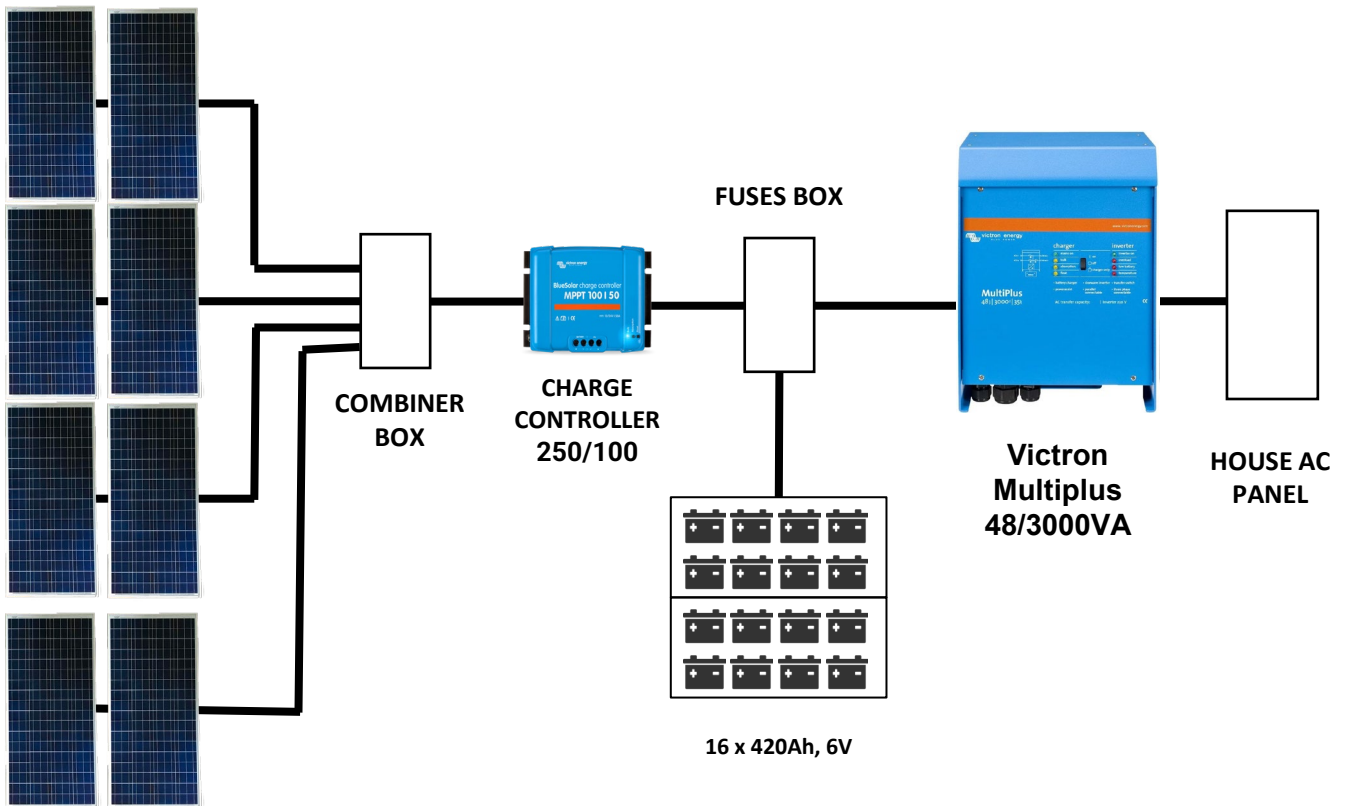

8 x 405W Solar Panel

*** Items is subject to change

PRICING

8	405 WATT, MONO PANEL
1	MNPV6
4	MNEPV15 Breakers
1	SmartSolar MPPT 250/100
1	Victron Multiplus 48/3000VA
16	B6-400B Battery 6V, 420 Ah
1	BMV 702 Battery Shunt
1	Cables and Materials
1	Inverter Breaker & DC disconnect
1	20m 10/2 tec

Total	\$25,092.59
--------------	--------------------

***Installation not included.
***Optional upgrade to lithium.
***Tax not included

RACKING OPTION

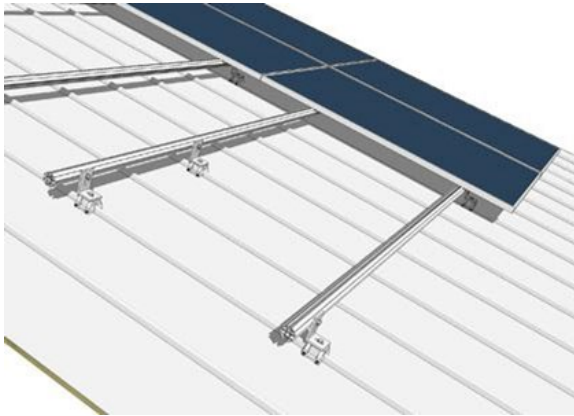

Either on roof or ground our off-grid systems packages comes with multiple options to choose from. The racking systems are designed to be easily installed without compromising roof warranties.

Our ground mount racking system is the ideal solution for bad roof condition (maintenance, replacement, sloped roofs), high temperatures (cooler panels mean more power), ease of system maintenance, size of system, shading issues, etc.

A ground mount solar system is a great choice for a home system if you have space and/or some challenges with a roof mounted system. With ground mounted solar panels, you can optimize your system power production by having the flexibility to adjust the ground racking angle. (facing south).

System	Cost
1 Panel Package	\$350.00
2 Panel Package	\$400.00
3 Panel Package	\$526.00
4 Panel Package	\$726.54
6 Panel Package	\$802.43
20 Panel Package	\$2,425.00
24 Panel Package	\$2,951.00

